

Sales Code: ENZW036

Barcode: 5056678428528

Brand: nuie

Description: Nuie 1700mm x 800mm Matt Black Frameless Walk-In Wetroom Screen Set With Tray



Technical Drawing Not Available

Product Dimensions

Product	1950 x 1200 x 14mm (H x W x D)
Nett Weight	123.21 kg
Packaged Weight	124.1 kg

Product Details

Country of Origin	China
Product Material	Acrylic Capped Abs Caco3 And Pu,Aluminium,Glass
Colour/Finish	Matt Black
Style	Contemporary
Enclosure Design	Frameless
Glass Thickness	8 mm
Waste Included	No

Sales Code: WRSB1200G

Barcode: 5056460000000

Brand: OEM

Description: Missing title



Product Dimensions

Product	1950 x 1200 x 8mm (H x W x D)
Packaged	65 x 1250 x 2010mm (H x W x D)
Nett Weight	53.2 kg
Packaged Weight	53.2 kg

Product Details

Country of Origin	China
Easy Clean	No
Ce Certified	Yes
Easy Fit	No
Enclosure Design	Frameless
Glass Thickness	8 mm

Sales Code: WRSB800G

Barcode: 5056460000000

Brand: OEM

Description: Missing title



Product Dimensions

Product	1950 x 800 x 8mm (H x W x D)
Packaged	65 x 830 x 2010mm (H x W x D)
Nett Weight	35.9 kg
Packaged Weight	35.9 kg

Product Details

Country of Origin	China
Easy Clean	No
Ce Certified	Yes
Easy Fit	No
Enclosure Design	Frameless
Glass Thickness	8 mm

Sales Code: WRSF004

Barcode: 5056211807643

Brand: Hudson Reed

Description: Wetroom Wall Channel 1950mm Black Matt Black



Missing origin image

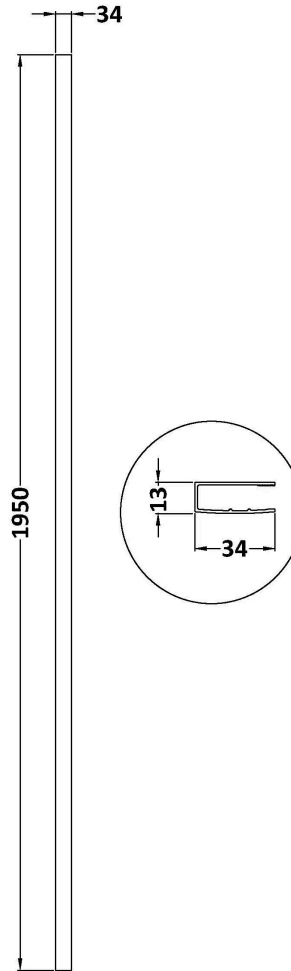

Product Dimensions

Product	1950 x 34 x 13mm (H x W x D)
Packaged	45 x 185 x 1970mm (H x W x D)
Nett Weight	1.01 kg
Packaged Weight	1.42 kg

Product Details

Country of Origin	China
Product Material	Aluminium
Colour/Finish	Matt Black
Style	Contemporary

Sales Code: FIX024

Barcode: 5056211847342

Brand: nuie

Description: Wetroom Screen Support Arm Matt Black

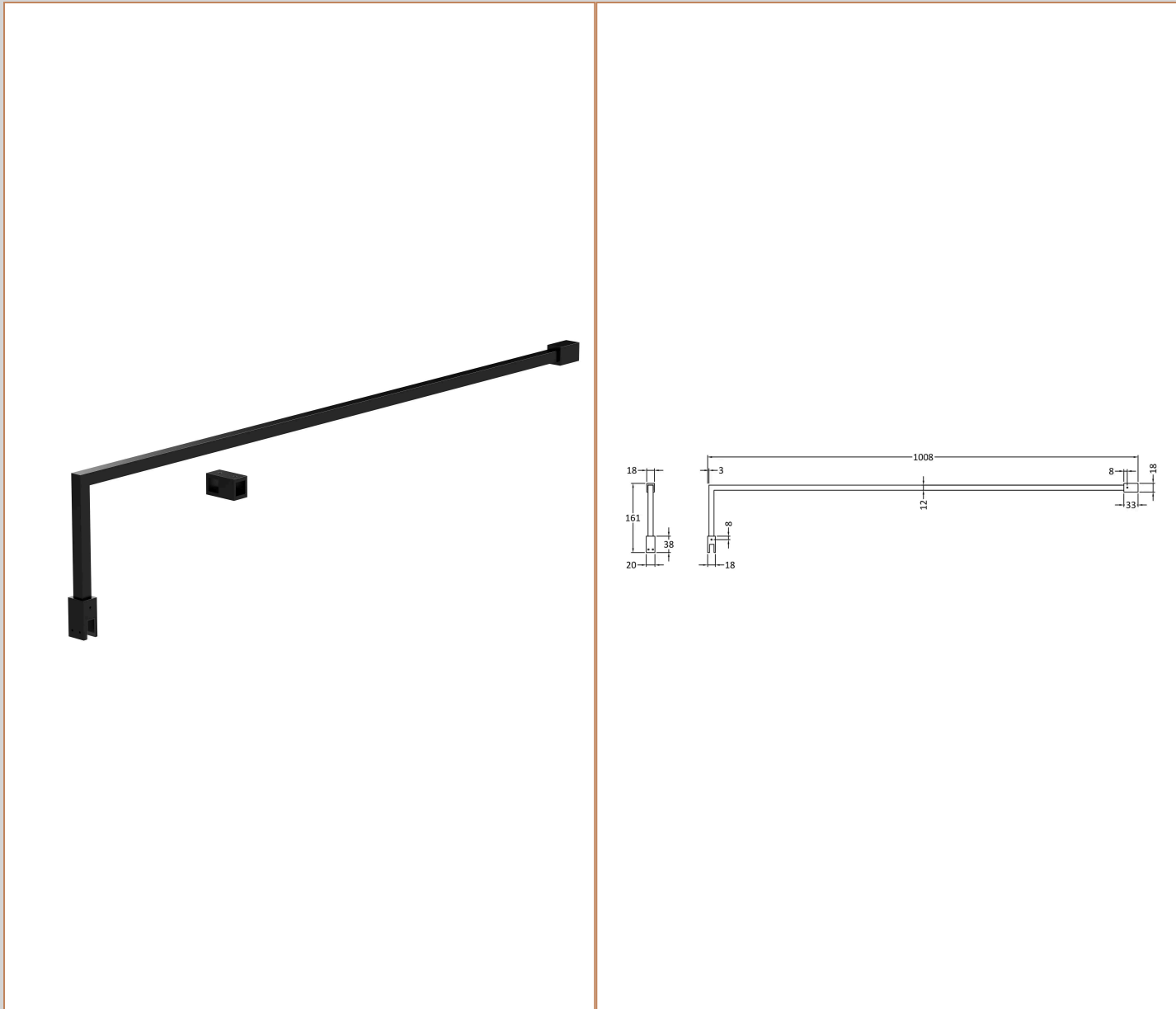

Product Dimensions

Product	15 x 150 x 1000mm (H x W x D)
Packaged	35 x 160 x 1020mm (H x W x D)
Nett Weight	0.67 kg
Packaged Weight	0.7 kg

Product Details

Country of Origin	China
Product Material	Stainless Steel
Colour/Finish	Matt Black
Style	Contemporary

Sales Code: NTP063

Barcode: 5055369006380

Brand: nuie

Description: Rectangular Slimline Shower Tray 1700 x 800mm

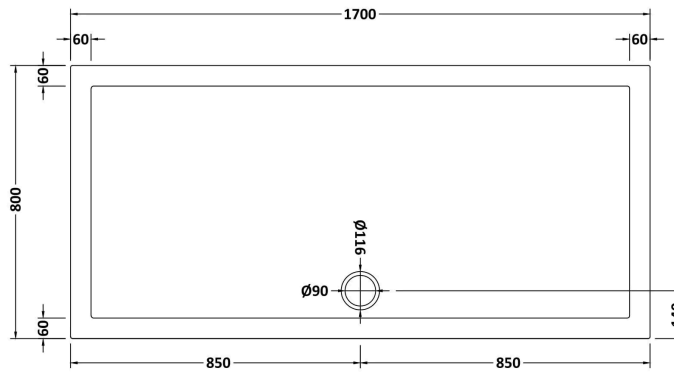

Product Dimensions

Product	40 x 800 x 1700mm (H x W x L)
Packaged	80 x 840 x 1740mm (H x W x D)
Nett Weight	43.2 kg
Packaged Weight	43.5 kg

Product Details

Country of Origin	United Kingdom
Product Material	Acrylic Capped Abs Caco3 And Pu
Colour/Finish	White
Style	Contemporary
Fixings Included	No
Leg Set Included	No
Legs Included	No
Raised Edge	Yes
Slip Resistant	No
Waste Included	No
Waste Size Required	90mm